

**ART. M145 CIN**

**REVOLVING HANDLE WITH STAINLESS STEEL RING NUT**

**INOX**

**MATERIAL:**  
Reinforced polyamide.  
Oils and greases resistant.

**SURFACE:**  
Satin.

**COLOUR:**  
Black (RAL 9011).

**REVOLVING INSERT:**  
Stainless steel (AISI 303) threaded stud with ring brass nut and wrench seat.

**SPECIAL REQUESTS:**

- It is possible to supply colours as shown in the table at page 29, on request and for quantities.

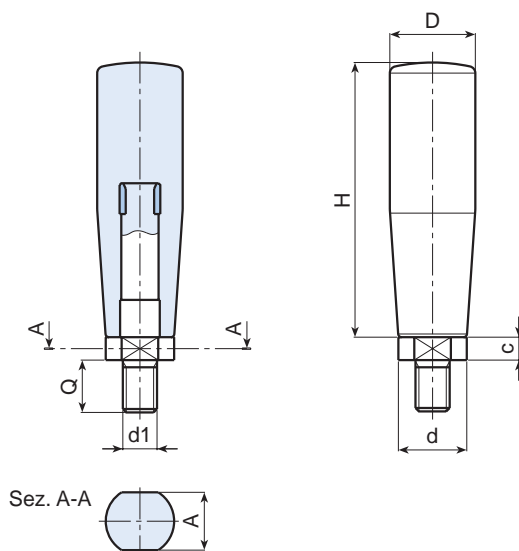

Art.	H	D	d	d1	c	A	Q	Weight (gr)
M14550.TM06X1201CIN	50	20	12	M06	5	10	12	32
M14560.TM08X1501CIN	60	23	18	M08	6	16	15	74
M14570.TM08X1501CIN	69	25	18	M08	7	16	15	82
M14570.TM10X1501CIN	69	25	18	M10	7	16	15	86
M14580.TM10X1501CIN	80	25	20	M10	7	17	15	92
M14580.TM12X1501CIN	80	25	20	M12	7	17	15	96
M14590.TM10X1501CIN	89	27	20	M10	7	17	15	104
M14590.TM12X1501CIN	89	27	20	M12	7	17	15	108



**BOTECA**